

Amplified system with subwoofer and satellites - 500W

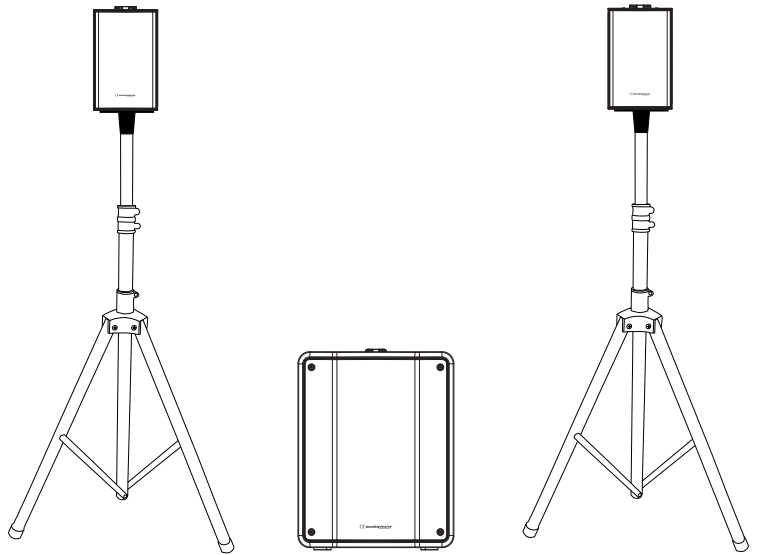

COMPACT500

1 - Safety information

Important safety information



This unit is intended for indoor use only. Do not use it in a wet, or extremely cold/hot locations. Failure to follow these safety instructions could result in fire, electric shock, injury, or damage to this product or other property.



Any maintenance procedure must be performed by a CONTEST authorised technical service. Basic cleaning operations must thoroughly follow our safety instructions.



This product contains non-isolated electrical components. Do not undertake any maintenance operation when it is switched on as it may result in electric shock.

Symbols used



This symbol signals an important safety precaution.



The WARNING symbol signals a risk to the user's physical integrity. The product may also be damaged.



The CAUTION symbol signals a risk of product deterioration.

Instructions and recommendations

1 - Please read carefully :

We strongly recommend to read carefully and understand the safety instructions before attempting to operate this unit.

2 - Please keep this manual :

We strongly recommend to keep this manual with the unit for future reference.

3 - Operate carefully this product :

We strongly recommend to take into consideration every safety instruction.

4 - Follow the instructions:

Please carefully follow each safety instruction to avoid any physical harm or property damage.

5 - Avoid water and wet locations :

Do not use this product in rain, or near washbasins or other wet locations.

6 - Installation :

We strongly encourage you to only use a fixation system or support recommended by the manufacturer or supplied with this product. Carefully follow the installation instructions and use the adequate tools.

Always ensure this unit is firmly fixed to avoid vibration and slipping while operating as it may result in physical injury.

7 - Ceiling or wall installation :

Please contact your local dealer before attempting any ceiling or wall installation.

8 - Ventilation :

The cooling vents ensure a safe use of this product, and avoid any overheating risk. Do not obstruct or cover these vents as it may result in overheating and potential physical injury or product damage. This product should never be operated in a closed non-ventilated area such as a flight case or a rack, unless cooling vents are provided for the purpose.

9 - Heat exposure :

Sustained contact or proximity with warm surfaces may cause overheating and product damages. Please keep this product away from any heat source such as a heaters, amplifiers, hot plates, etc...

CAUTION
RISK OF ELECTRIC SHOCK
DO NOT OPEN

WARNING : This unit contains no user-serviceable parts. Do not open the housing or attempt any maintenance by yourself. In the unlikely even your unit may require service, please contact your nearest dealer.
In order to avoid any electrical malfunction, please do not use any multi-socket, power cord extension or connecting system without making sure they are perfectly isolated and present no defect.

Sound levels

Our audio solutions deliver important sound pressure levels (SPL) that can be harmful to human health when exposed during long periods. Please do not stay in close proximity of operating speakers.

Recycling your device

- As HITMUSIC is really involved in the environmental cause, we only commercialise clean, ROHS compliant products.
- When this product reaches its end of life, take it to a collection point designated by local authorities. The separate collection and recycling of your product at the time of disposal will help conserve natural resources and ensure that it is recycled in a manner that protects human health and the environment.

10 - Electric power supply :

This product can only be operated according to a very specific voltage. These information are specified on the label located at the rear of the product.

11 - Power cords protection:

Power-supply cords should be routed so that they are not likely to be walked on or pinched by items placed upon or against them, paying particular attention to cords at lugs, convenience receptacles and the point where they exit from the fixture.

12 - Cleaning precautions :

Unplug the product before attempting any cleaning operation. This product should be cleaned only with accessories recommended by the manufacturer. Use a damp cloth to clean the surface. Do not wash this product.

13 - Long periods of non use :

Disconnect the unit's main power during long periods of non use.

14 - Liquids or objects penetration :

Do not let any object penetrate this product as it may result in electric shock or fire. Never spill any liquid on this product as it may infiltrate the electronic components and result in electric shock or fire.

15 - This product should be serviced when :

Please contact the qualified service personnel if :

- The power cord or the plug has been damaged.
- Objects have fallen or liquid has been spilled into the appliance.
- The appliance has been exposed to rain or water.
- The product does not appear to operate normally.
- The product has been damaged.

16 - Inspection/maintenance :

Please do not attempt any inspection or maintenance by yourself. Refer all servicing to qualified personnel.

17 - Operating environment :

Ambient temperature and humidity: +5 - +35°C, relative humidity must be less than 85% (when cooling vents are not obstructed).

Do not operate this product in a non-ventilated, very humid or warm place.

2 - Technical specifications

SATELLITE

Power	80W RMS - 160W max
Frequency response	155Hz -22KHz
Sensitivity(1W@1m)	93 dB
Max. SPL (@1m)	120 dB
Nominal impedance	8 Ohms
Boomer	4.75"
Tweeter	1" compression
Dispersion	90° x 45° (HxV)
Connector	1 x Jack
Fixation system	1 x M6 insert and 18 mm mounting plate
Dimensions	225 x 140 x 110 mm
Net weight	1.9 kg

SUBWOOFER

Power	350W RMS - 700W max
Frequency response	50 - 160Hz
Sensitivity(1W@1m)	90 dB
Max. SPL (@1m)	120 dB
Boomer	10"
Fixation system	1 x 25 mm mounting plate (on top)
Dimensions	345 x 450 x 400 mm
Net weight	14.5 kg

AMPLIFICATION

Low frequencies	1 x 350W RMS / Class D - 4 Ohms
Mid/High frequencies	2 x 80W RMS / class D - 8 Ohms
Inputs	3 x Combo XLR / Jack 1 x Line / Mic 1 x RCA / 1 x Jack 3.5 stereo line
Outputs	2 x Jack line level 1 x Jack link 2 x Jack for satellites
DSP	Vocal-Flat-Music for each input
Level	Volume settings for each way
Sub	Main volume settings
Balance	Left/Right volume control
Selectors	1 x CH2 thru/RECOut 1 x Satellites mono or stereo setup

3 - Presentation

3-1 Overview

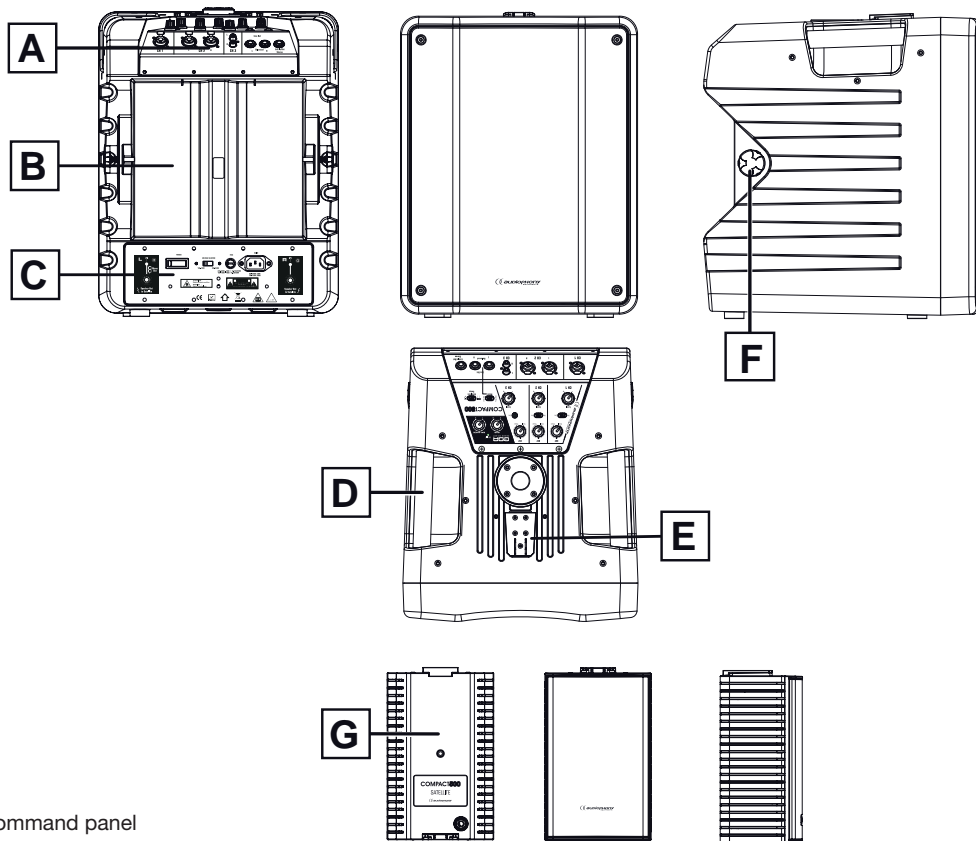

A - Command panel

B - Satellites compartment

C - Power supply and satellites connectors zone

D - Transport handle

E - Male audio contact slot

F - Satellites clamping knob

G - Satellite

A- Rear view

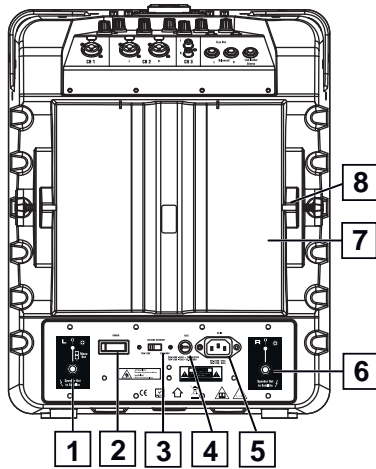

1 - Satellite output for either a stereo left satellite or two mono satellites.



CAUTION: only the COMPACT500 satellites can be connected via this output.

2- Power switch

3 - Voltage selector: Allows you to adapt the voltage of the amplifier to the voltage of the electrical outlet.

4 - Fuse: Protects the power supply module and the built-in amplifier.

If need to replace the fuse, please make sure the new fuse has exactly the same characteristics.

5- Power input socket: Allows you to connect the speaker to an electrical outlet. Use the supplied IEC cord, and make sure the voltage delivered by the outlet is in adequation with the value indicated by the voltage selector before turning on the built-in amplifier.

6- Output for stereo right satellite.



CAUTION: only a COMPACT500 satellite can be connected via this output.

7- Satellites storage compart

8- Clamping knob to secure the satellite once in its compartment. Use the insert at the rear of the satellite to tighten it safely.

3.2 - More details about the command panel of the subwoofer:

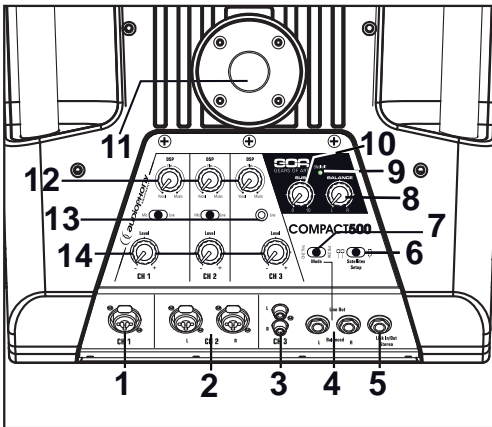

1 - CH1 input via balanced COMBO

Connect here an XLR or JACK plug from a line level music instrument or a microphone. The signal of this mono input is spread across the right and left output of the system.

2 - CH2 inputs via balanced stereo COMBO

Connect here XLR or JACK plugs from a line level music instrument. The left channel can be used by a microphone.

3- CH3 inputs via RCA and stereo Jack 3.5 -

Connect an external player or a line level instrument via RCA. The AUX input allows you to connect via stereo Jack 3.5 any extra line level source.

4- Balanced L and R line level outputs

Allows you to retrieve the incoming signal to transmit it (e.g. to active speakers). Depending on the selector No. 7, the output will only transmit the signal of channel 2, or of the whole system.

5- Balanced stereo link

Allows you to daisy-chain several COMPACT500. Please use a stereo Jack / Jack 6.35 cable.

6- Satellites output configuration

Left selector: Stereo mode if both outputs are active and the two satellites separated to be used as a 2.1 sound system.

Right selector: Mono mode, the left output only is active and the two satellites are linked together to focus their power on one single side. In this mode, a second COMPACT500 sound system can be connected to the output No. 5 to double the power output.

7- Line output mode

Allows you to choose the signal injected to the outputs No. 4.

Left selector: The Line Out output only transmits the CH2 signal.

Right selector: The whole signal is transmitted from the system to the Line Out outputs.

8 - Balance

Allows you to adjust the distribution of the signal on the left and right satellites.

9 - ON/LIMIT signal indicator

Allows you to check on the volumes

(PLEASE MAKE SURE EACH CHANNEL IS CONFIGURED IN ORDER TO PREVENT THIS INDICATOR FROM BEING LIT)

10 - Subwoofer sound level

The subwoofer volume can be adjusted separately. Use this knob to adjust it as desired. By default, the system is balanced when this knob is in middle position.

(PLEASE MAKE SURE TO CONFIGURE IT IN ORDER TO PREVENT THE LIMIT FROM BEING LIT)

11 - Mounting plate

Allows you to insert a 35 mm tube to pole-mount satellites. One of the tubes of the supplied speaker stand can be used to mount your satellites.

12 - Channels 1 to 3 DSP

This setting allows you to adjust the sound of each channel to meet your needs. When on the left, the sound is very neutral and is perfect for vocal uses: basses and trebles are dimmed. In the middle position, the correction remains neutral and respects the original source, toward the right, mediums are lowered while basses and trebles are reinforced to produce a more dynamic output.

13 - Channels 1 to 3 input selector

Allows you to choose the type of source connected to each channel.

14 - Channels sound level

Allows you to adjust the sound level of each channel.

This setting also affects the main volume level of the amplification system.

(PLEASE MAKE SURE TO CONFIGURE IT IN ORDER TO PREVENT THE LIMIT FROM BEING LIT)



Please make sure to properly configure the sound levels of your system. In addition to being unpleasant for the audience, improper settings can damage your whole sound system.

The "LIMIT" indicators will light on when the maximum level is reached and must never be permanently lit.

Beyond this maximum level, the volume will not increase but will be distorted.

Moreover, your system can be destroyed by an excessive sound level despite of the internal electronic protections.

First, in order to prevent that, adjust the sound level via the Level of each channel.

Then, use the DSP to adjust the acoustic as you wish.

Finally, adjust the volume of the subwoofer.

If the sound output does not seem powerful enough, we strongly recommend to multiply the number of systems or satellites in order to spread the sound output evenly.

3.3 - Satellites:

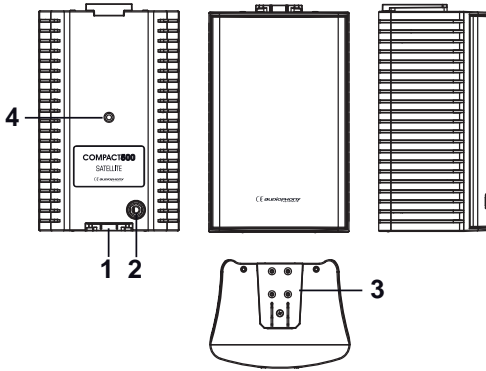

Satellite of the COMPACT system:

- 1 - Female audio contact slot
- 2 - Jack 6.35 In
- 3 - Male audio contact slot
- 4 - M6 insert



The satellites were designed to be operated with this subwoofer. Please do not use any other type of satellites as it may damage the whole sound system.

4 - Setting up the sattelites

4.1 - Using a speaker stand

The COMPACT 500 satellites can be equipped with an accessory featuring a 18mm baseplate to mount them on a compatible speaker stand, as described on the drawing opposite.



Please respect the following safety precautions when using speaker stands:

- When using speakers stands outdoors, please make sure the stands are secured, even perhaps guyed, in order to prevent any risk of fall.
- If the speaker stands are in a crowded area, make sure to prevent the audience from accessing them.
- When mounting the stands, make sure to spread the tripod as much as possible to stabilise the stand.
- Please make sure to install your stands on a flat, even surface.
- Tighten the clamping knobs properly before turning the speakers on.

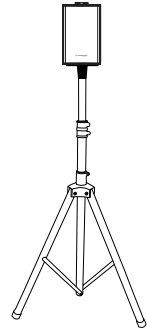

4.2 - Setting up two satellites together

The COMPACT500 satellites are equipped with male and female contact slots allowing them to be daisy-chained.

This slot guarantees the transmission of the audio signal between the two satellites and the mechanical connection.

The opposite drawing describes how to connect two satellites.

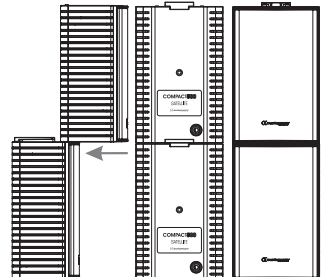

4.3 - Setting up the satellites above the subwoofer

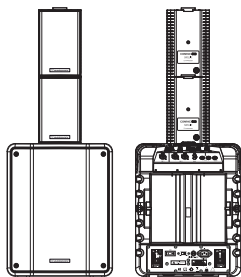

The COMPACT500 satellites can be directly mounted above the subwoofer thanks to its contact slot.

This slot guarantees the transmission of the audio signal between the two satellites and the subwoofer. Cables are not required in this case.

The drawing opposite describes speakers mounted above the subwoofer.

The COMPACT500 satellites can also be pole-mounted above the subwoofer thanks to the upper part of one of the supplied speaker stands.

The bar must be inserted into the 25 mm mounting plate of the subwoofer and into the 18 mm mounting plate of the lower satellite.

The drawing opposite describes this installation.

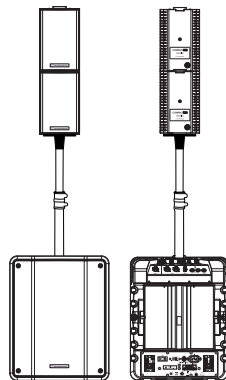

5 - Basical wiring

5.1 - Using the COMPACT500 as 2.1 system:

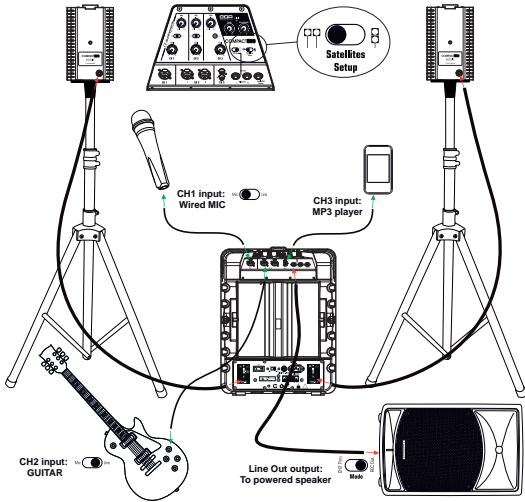

The COMPACT500 system can be used, for instance, for a guitar player-singer with soundtrack.

To do so, proceed as follows:

- The microphone will be plugged to the CH1 combo input via XLR socket, the selector will be in MIC position.
- The guitar will be connected to the left CH2 balanced jack socket.
- The MP3 player will be connected to the CH3 RCA socket.
- The satellites are in stereo mode and will be plugged to the SPEAKER OUT L and R Jack sockets.
- The amplified monitoring speaker will be connected to the LINE OUT L output. The selector in REC out position allows the whole signal to be sent to the monitoring speaker.

5.2 - Using the COMPACT500 as a mono 1.1 system:

The COMPACT500 system can be used, for instance, to give voice to a conference via a speaker and computer.

To do so, proceed as follows:

- The microphone will be connected to the CH1 combo input via XLR socket, the selector in MIC position.
- The computer will be connected to the CH3 input via RCA.
- The satellites are in mono mode, directly set up onto the subwoofer via the connection slot, which will transmit the signal between the two satellites.

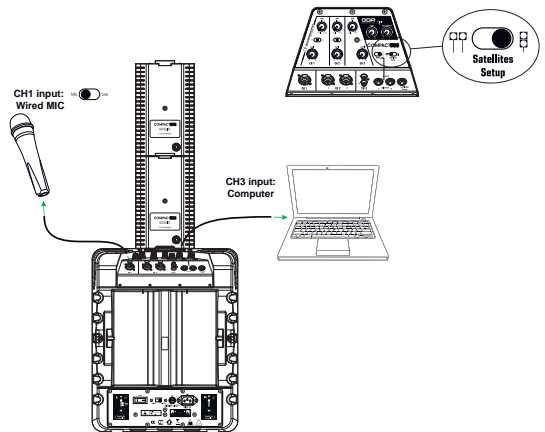

5.3 - Double mono 1.1 cabling of two COMPACT500 systems:

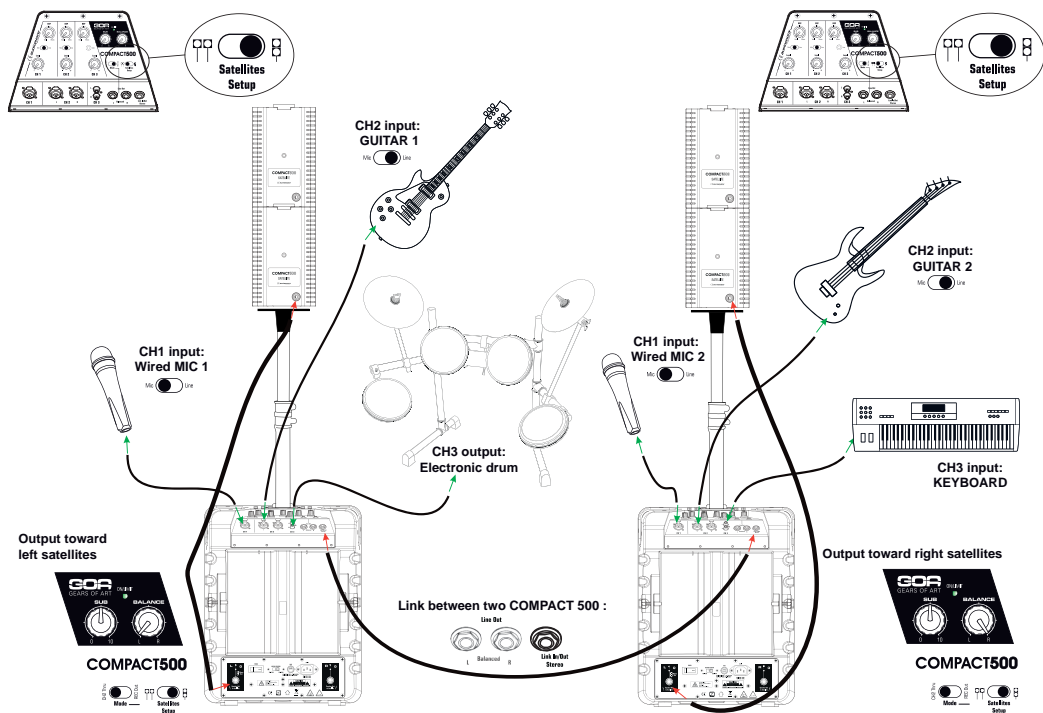

Two COMPACT500 systems can be combined together to increase the sound diffusion and the number of inputs. In this example, the two COMPACT500 systems are used by a small formation of two guitarists and singers, a keyboard and the percussions.

To do so, the wiring will be as follows:

For the COMPACT500 on the left:

- The microphone 1 will be connected to the CH1 combo input via XLR plug, the selector must be in MIC position.
- The guitar 1 will be connected to the left CH2 balanced Jack plug, the selector must be in LINE position.
- The drum kit will be connected to the CH3 input via RCA plugs.
- The satellites are in mono mode and directly connected via the contact slots. The balance is in the left position.

For the COMPACT500 on the right:

- The microphone 2 will be connected to the CH1 combo input via XLR plug, the selector must be in MIC position.
- The guitar 2 will be connected to the left CH2 balanced Jack plug, the selector must be in LINE position.
- The electronic keyboard will be connected to the CH3 input via RCA plugs.
- The satellites are in mono mode and directly connected via the contact slots. The balance is in the right position.

- The connection between the two COMPACT500 is guaranteed by the stereo LINK In/Out via a balanced Jack / Jack cable.

6 - Dimensions

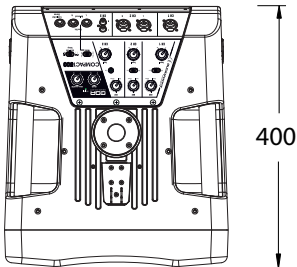
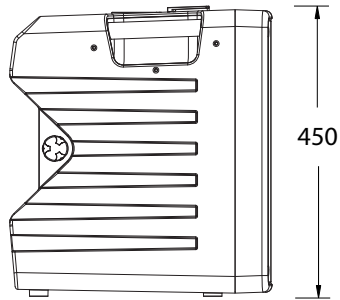
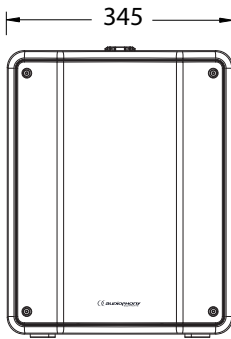
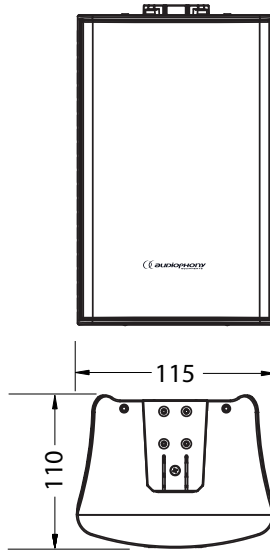
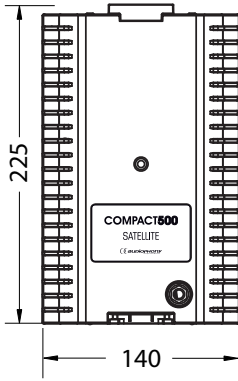

Because AUDIOPHONY® takes the utmost care in its products to make sure you only get the best possible quality, our products are subjects to modifications without prior notice. That is why technical specifications and the products physical configuration might differ from the illustrations.

Make sure you get the latest news and updates about the AUDIOPHONY® products on www.audiophony.com
AUDIOPHONY® is a trademark of HITMUSIC S.A. - Zone Cahors sud - 46230 FONTANES - FRANCE