



ELECTRIC HOIST 1000 KG KBA-202 BVG D8 +

Regulatory chord BGV D8 +

KBA, the "inverted" hoist for shows Specially designed for stage applications. The KBA boasts a proven robust industrial design with the following application-specific adaptations:

- Inverted special roller for a perfect chain exit. -
- Aluminum crankcase cover for less weight of the equipment.
- Special large capacity bag.
- Painted in black.
- KBA construction with reversed swivel hook or with eyelet (to be determined)
- Special three-phase lifting motor with high starting torque.
- Protection degree for motors and insulation:
- **IP55** (optional other protections) / Class F
- Maintenance-free gearbox, motor, load limiter and double brake.
- Paint C2 (according to ISO -12944) finished in black (optional other treatments)

Normative

Hoist built and tested in accordance with the European Machinery Directive 2006/42 / CE and UNE, EN and FEM standards indicated in the CE certificate.

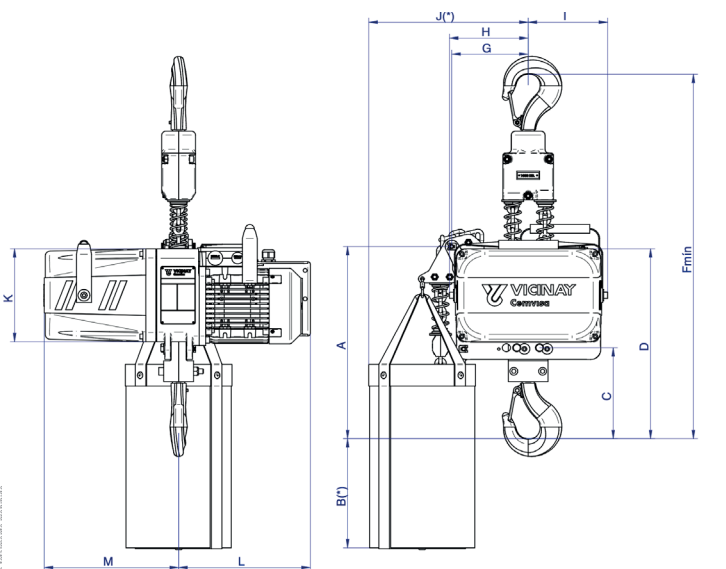

Dimensions

A	B*	C	D	Fmin	G	H	I	J	K	L	M
398	226	188	394	755	154	159	160	321	193	265	272

Characteristics

- Model: KBA 202-1004U
- Local capacity: 1.000 kg
- Dimension between hools (mm): 755
- Number of chain brachers: 2
- Chain diamete (mm): 7
- Hook travel (m): To determinate
- Lifting speed (S) M/min): 4
- Lifting motor power (KW): 0,75 kW
- Supply voltage: III-400V-50Hz
- Control by keypad: Optional
- Junction box on the hoist itself: Included
- Control pendant hose length (m): n/a
- Chaing bag: Included
- Load limiter: Included
- Upper and lower electrical limit switches: Included
- Rotating upper and lower hooks: Included
- Double electromagnetic brake: Included
- Ergonomic carry handles: Included