

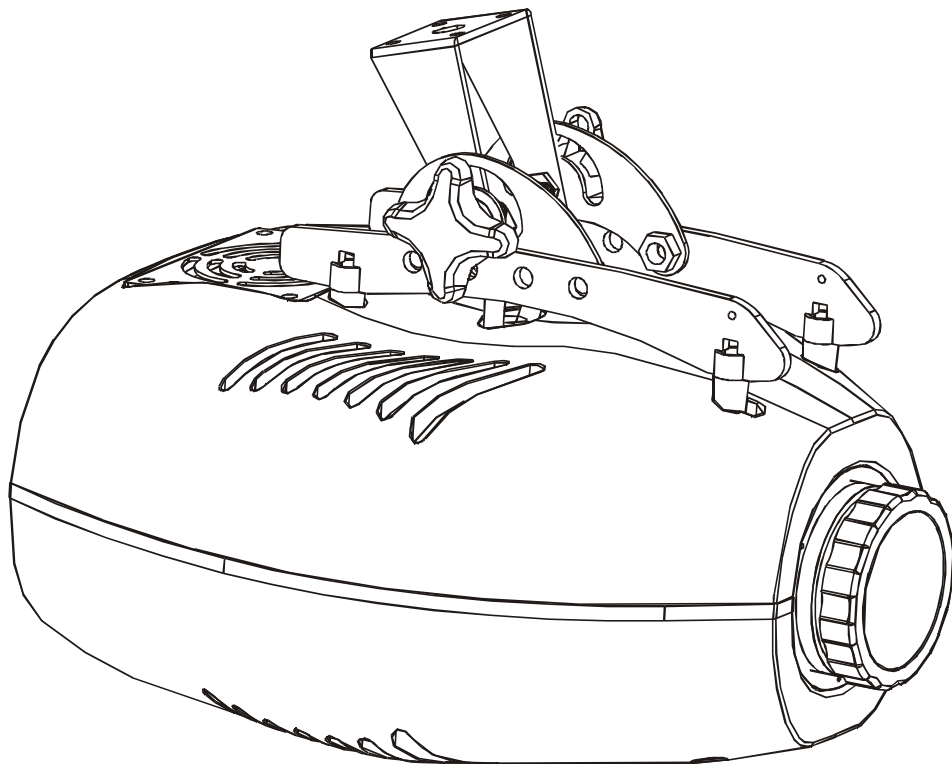

PROFESSIONAL LIGHT USER'S MANUAL

MF-5



KEEP THIS MANUAL FOR FUTURE NEEDS



For your own safety, please read this user manual carefully before installing the device.

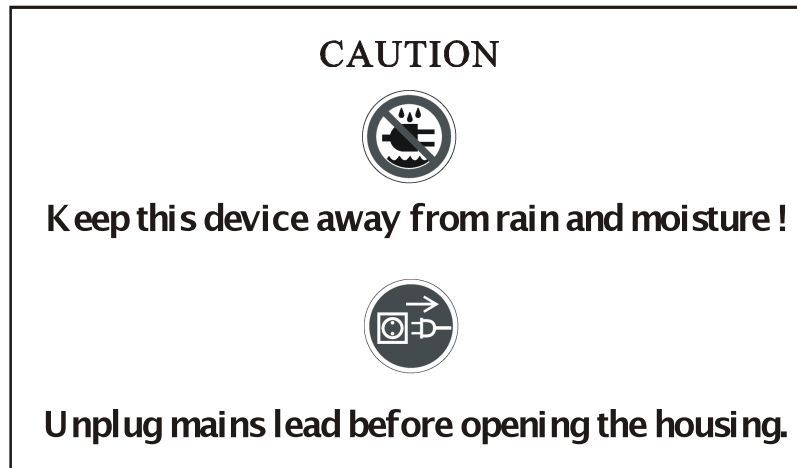

Every person involved with the installation, operation and maintenance of this device has to:

- be qualified
- follow carefully the instructions of this manual

INTRODUCTION:

Thank you for having chosen this professional moving head.
You will see you have acquired a powerful and versatile device.

Unpack the device. Inside the box you should find: the fixture device, a power cable, an XLR connection cable, a safety cable and this manual. Please check carefully that there is no damage

Overview:

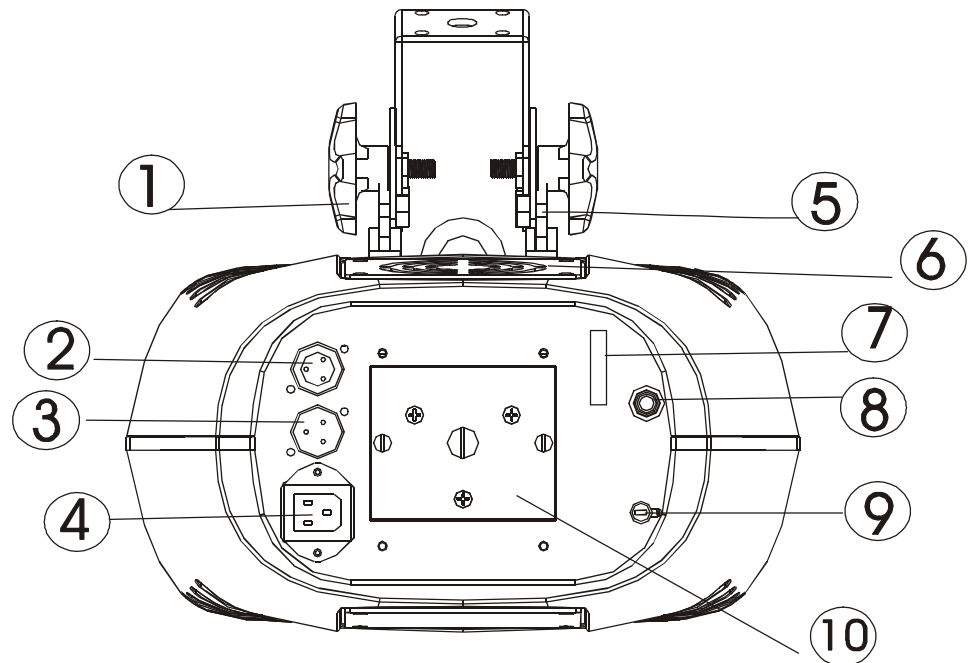

- (1) Fixation screw
- (2) DMX-In socket
- (3) DMX-Out socket
- (4) Power supply/Fuse holder
- (5) Mounting bracket
- (6) Ventilator
- (7) DIP-switches
- (8) Blackout controller jack
- (9) MIC Sensitivity-button
- (10) Lamp system

Features

- Lamp: Philips MSD 250/2 8500K, base : GY 9.5
- Control signal: standard DMX-512, 5 channels
- Stand alone operation with master/slave function, can be sound activated
- special color wheel with multi color pieces can make rainbow effect in both direction
- One gobo wheel with 5 rotating gobos, with gobo shaking, and black out
- Prism and prism rotation

- Preset program: 8 built in programs can be called up via DMX controller

SAFETY INSTRUCTIONS



CAUTION

Be very careful during installation. Since you will be working with a dangerous voltage you can suffer a life-threatening electric shock when touching live v

This device has left the factory in perfect condition. In order to maintain this condition and to ensure a safe operation, it is absolutely necessary for the user to follow the safety instructions and warning notes written in this user manual.

IMPORTANT

Damages caused by the disregard of this user manual are not subject to warranty. The dealer will not accept liability for any resulting defects or problems.

If the device has been exposed to temperature changes due to environmental changes, do not switch it on immediately. The arising condensation could damage the device. Leave the device switched off until it has reached room temperature.

This device falls under protection-class I. Therefore it is essential that the device should be earthed.

The electric connection must carry out by qualified person.

Make sure that the available voltage is not higher than stated at the end of this manual. Make sure the power cord is never crimped or damaged by sharp edges. If this would be the case, replacement of the cable must be done by an authorized dealer.

Always disconnect from the mains, when the device is not in use or before cleaning it. Only handle the power cord by the plug. Never pull out the plug by tugging the power cord.

During initial start-up some smoke or smell may arise. This is a normal process and does not necessarily mean that the device is defective, it should decrease gradually.



Please be aware that damages caused by manual modifications to the device are not subject to warranty. Keep away from children and non-professionals.

GENERAL GUIDELINES

This device is a lighting effect for professional use on stages, in discotheques, theatres, etc. This fixture is only allowed to be operated with the max alternating current which stated in the technical specifications in the last page of this manual, the device was designed for indoor use only.

Lighting effects are not designed for permanent operation. Consistent operation breaks may ensure that the device will serve you for a long time without defects. Do not shake the device.

Avoid brute force when installing or operating the device.

While choosing the installation-spot, please make sure that the device is not exposed to extreme heat, moisture or dust. The minimum distance between light-output from the projector and the illuminated surface must be more than 0,5 meter.

Always fix the fixture with an appropriate safety cable if you use the quick lock cam in hanging up the fixture, please make sure the 4 quick lock fasteners turned in the quick lock holes correctly.

Operate the device only after having familiarized with its functions. Do not permit operation by persons not qualified for operating the device. Most damages are the result of unprofessional operation.

Please use the original packaging if the device is to be transported.

For safety reasons, please be aware that all modifications on the device are forbidden.

If this device will be operated in any way different to the one described in this manual, the product may suffer damages and the guarantee becomes void. Furthermore, any other

operation may lead to short-circuit, burns, electric shock, lamp explosion, crash, etc.

INSTALLATION INSTRUCTIONS

a) *Installing or replacing the lamp*



Before replacing the lamp let the lamp cool down, because during operation, the lamp can reach very high temperature.

During the installation of halogen lamps do not touch the glass bulbs bare handed. Always use a cloth to handle the lamps during insertion and removal.

Do not install lamps with a higher wattage. They generate higher temperatures than which the device was designed for.

For the installation, you need one: MSD 250/2

Procedures:

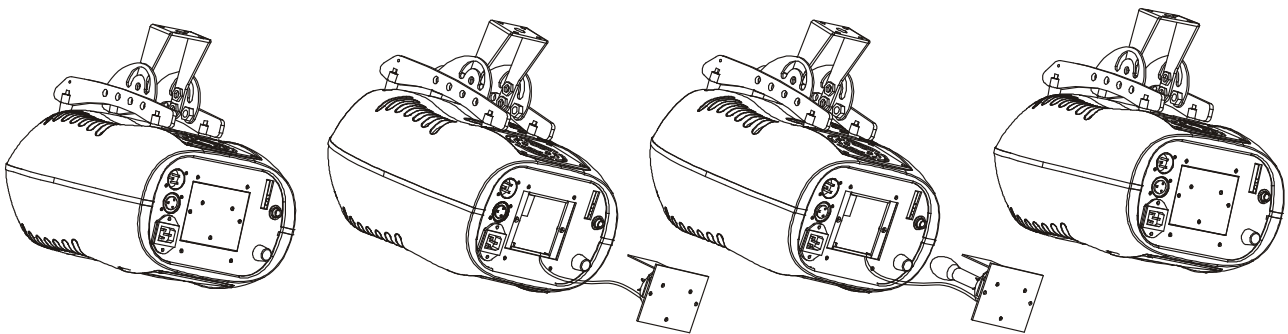

- 1) Unscrew the 2 screws (A,B) on the bottom of the housing, holding the plate where the lamp is underneath. Carefully remove the metal plate.
- 2) Carefully insert the lamp into the socket. Please remember there is only one way to insert the lamp. Gently slide the lamp and its lamp holder back into place.
- 3) On the access plate there are 3 screws marked 1,2 and 3, which are used to adjust the lamp holder in the lamp housing. You can adjust the 3 screws to fine-tune the position of the lamp to get the maximum light output as shown below.

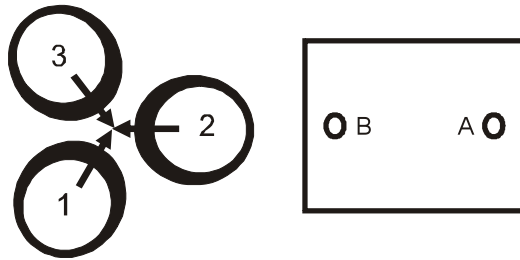

Please remember the lamp is not a hot-restrike type, you must wait for approximately 10 minutes after having turned off the lamp before you can turn it back on again.



b) Mounting the device



The installation of the effect has to be built and constructed in a way that it can hold 10 times the weight for 1 hour without any harming deformation.

The installation must always be secured with a secondary safety attachment, e.g. an appropriate safety cable.

Never stand directly below the device when mounting, removing or servicing the fixture.

The operator has to make sure the safety relating and machine technical installations are approved by an expert before taking the device into operation for the first time.

These installations have to be approved by a skilled person once a year.



Cautions:

The effect should be installed outside areas where persons may reach it, walk by or be seated.



Overhead mounting requires extensive experience, including amongst others calculating working load limits, installation material being used, and periodic safety inspection of all installation material and the device. If you lack these qualifications, do not attempt the installation yourself. Improper installation can result in bodily injury.



Before mounting make sure that the installation area can hold a minimum point load of 10 times the device's weight.

Connect the fixture to the mains with the power plug.

installation via the clamp

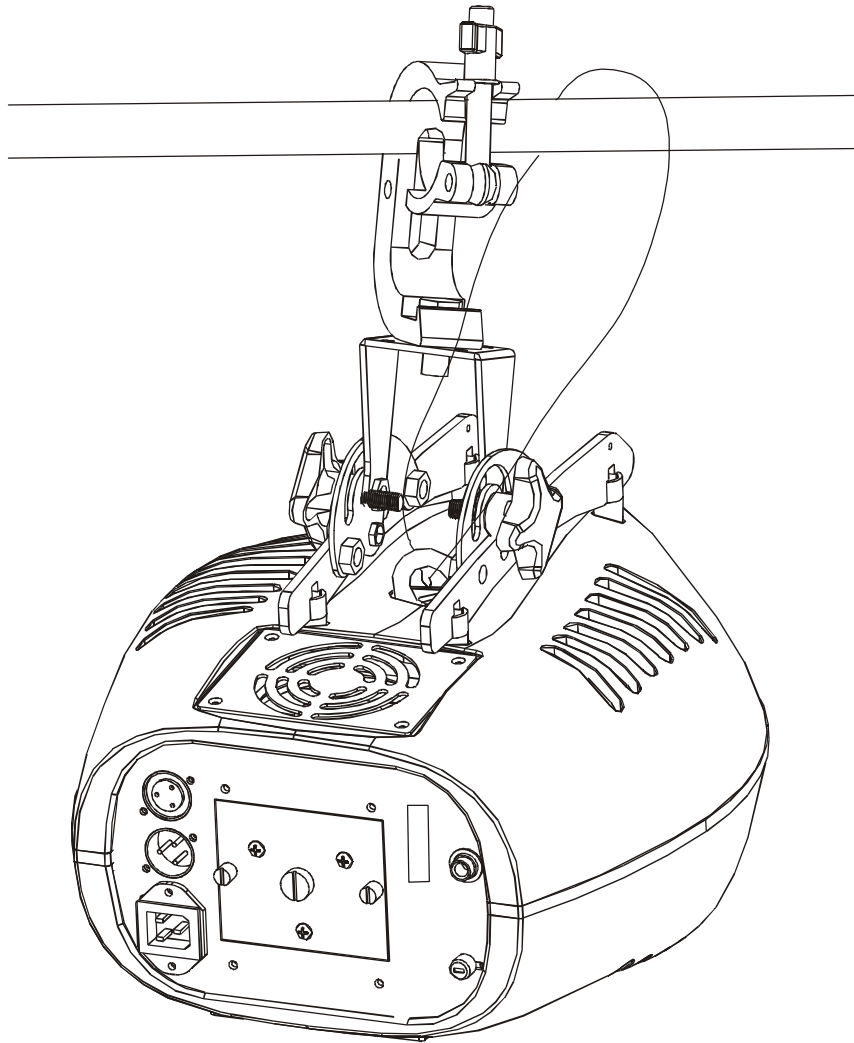

Screw one clamp each via a M10 screw and nut directly into the bracket of the unit. Pull the safety-chain through the eyelet on the rear of the unit and over the trussing system or a safe fixation spot.

Master/Slave-operation

The master/slave-operation enables that several devices can be synchronized and controlled by one master-device. On the rear panel of the LIGHTING EFFECT you can find an XLR-jack (DMX Out) and an XLR-plug (DMX In), which can be used for connecting several devices.

Choose the device which is to control the effects. This device then works as master-device and controls all other slave-devices, which are to be connected to the master-device via a balanced microphone lead. Connect the DMX OUT-jack with the DMX IN-plug of the next device.

Set DIP-switch No. 11 to On for the master-device. Set DIP-switch No. 1 to on for all slave-devices.

Occupation of the DIP-switches:

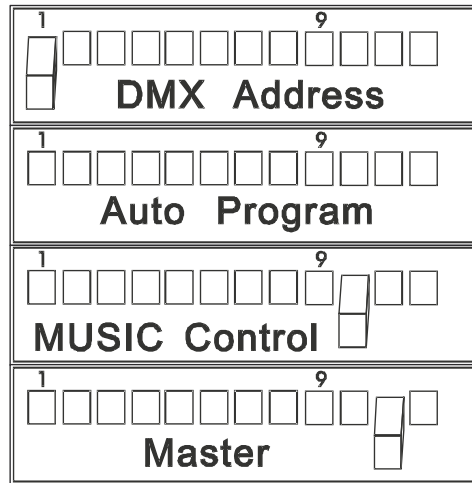

Blackout-socket

If you wish to lock the light output - e.g. via an optional footswitch (Blackout-mode), connect your footswitch via a mono-jack plug to the Blackout-socket.

Occupation mono 1/4" jack-plug:

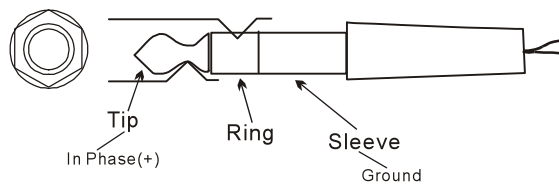

DMX-512 connection / connection between fixtures

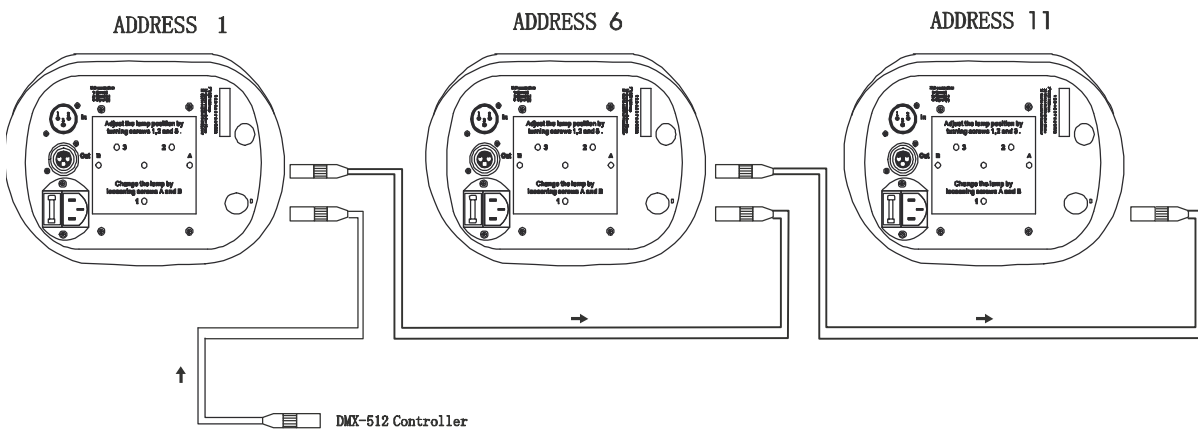

Only use a stereo shielded cable and 3-pin XLR-plugs and connectors in order to connect the controller with the fixture or one fixture with another.

Occupation of the XLR-connection:

DMX -output
XLR mounting-socket



1:Ground
2:Signal(-)
3:Signal(+)

DMX -input
XLR mounting-socket



1:Ground
2:Signal(-)
3:Signal(+)

If you are using controllers with this occupation, you can connect the DMX-output of the controller directly with the DMX-input of the first fixture in the DMX-chain. If you wish to connect DMX-controllers with other XLR-outputs, you need to use adapter-cables.

Building a serial DMX-chain:

Connect the DMX-output of the first fixture in the DMX-chain with the DMX-input of the next fixture. Always connect one output with the input of the next fixture until all fixtures are connected.

DMX-512 connection with DMX terminator

For installations where the DMX cable has to run a long distance or is in an electrically noisy environment, such as in a discotheque, it is recommended to use a DMX terminator. This helps in preventing corruption of the digital control signal by electrical noise. For normal products which do not have dip switches setting, the DMX terminator is simply an XLR plug with a 120 Ω resistor connected between pins 2 and 3, which is then plugged into the output XLR socket of the last fixture in the chain.

While on the MF-5 which with the dip Switches setting, if the DP12 is put to ON position (downwards) the fixture gains the function of connecting with a 120 Ω resistor, then this unit functions as the terminator of the DMX link.

Addressing

Each projector occupies 5 channels. To ensure that the control signals are properly directed to each projector, the projector requires addressing. This is to be done for every single projector by changing the DIP switches as set out in this table.

The starting address is defined as the first channel from which the LIGHTING EFFECT will respond to the controller.

Please make sure that you don't have any overlapping channels in order to control each LIGHTING EFFECT correctly and independently from any other fixture on the DMX data link. If two, three or more LIGHTING EFFECT are addressed similarly, they will work similarly.

Occupation of the DIP-switches:

Setting the DMX-starting address:	DIP-switch no.	1	2	3	4	5	6	7	8	9
Projector number & channels	DMX-starting address	1	2	4	8	16	32	64	128	256
Device 1 - channels 1-5	On	▲								
	Off		▼	▼	▼	▼	▼	▼	▼	▼
Device 2 - channels 6-10	On		▲	▲						
	Off	▼			▼	▼	▼	▼	▼	▼
Device 3 - channels 11-15	On	▲	▲		▲					
	Off			▼		▼	▼	▼	▼	▼
Device 4 - channels 16-20	On					▲				
	Off	▼	▼	▼	▼		▼	▼	▼	▼
Device 5 - channels 21-25	On	▲		▲		▲				
	Off		▼		▼		▼	▼	▼	▼

Connection with the mains

Connect the device to the mains with the enclosed power supply cable.

The occupation of the connection-cables is as follows:

Cable	Pin	International
Brown	Live	L
Blue	Neutral	N
Yellow/Green	Earth	

The earth has to be connected!

If the device will be directly connected with the local power supply network, a disconnection switch with a minimum opening of 3 mm at every pole has to be included in the permanent electrical installation.

Lighting effects must not be connected to dimming-packs.

OPERATION

After you connected the effect to the mains, the LIGHTING EFFECT starts running. During the Reset, the motors are trimmed and the device is ready for use within approximately 20 seconds.

Turn the objective-lens for adjusting the focus in order to obtain a sharp projection.

Stand Alone operation

In the Stand Alone mode, the LIGHTING EFFECT can be used without controller. You can do without a controller as the LIGHTING EFFECT features a built-in microphone, which provides automatic sound control. Disconnect the LIGHTING EFFECT from the controller

and set the DIP-switch 10 to On.

The lamp is automatically ignited as soon as the condenser microphone receives music signals.

Call up the Auto program

In order to call up the Auto program, set all DIP-switches to Off.

Master/Slave-operation

Connect the master and slave-devices as desired above and set the DIP-switches accordingly.

Please note: If you wish to change from one operating mode into another, you either have to switch off the lamp/activate Blackout-mode or unplug the projector from the mains and plug it again.

Auto Program MIC SENSITIVITY-button

1. Put the Dip-switch in the sound mode and adjust the sensitivity of the activated sound by turning the MIC SENSITIVITY-button.
2. In the Auto Program mode (all Dip-switches to OFF) you can select different internal programs with this button.

DMX-controlled operation

You can control the projectors individually via your DMX-controller. Every DMX-channel has a different occupation with different features.

DMX channel´s functions and their values (5 DMX channels):

Channel 1 - Color:

- | | |
|---------|--|
| 0-127 | Color indexing |
| 128-187 | Forwards rainbow effect from fast to slow |
| 188-193 | No rotation |
| 194-255 | Backwards rainbow effect from slow to fast |

Channel 2 - Rotating gobos, cont. rotation :

- | | |
|---------|---------------------|
| 0-3 | Close |
| 4-7 | Close & Motor reset |
| 8-19 | Close |
| 20-39 | Rot. gobo 1 |
| 40-59 | Rot. gobo 2 |
| 60-79 | Rot. gobo 3 |
| 80-99 | Rot. gobo 4 |
| 100-120 | Rot. gobo 5 |
| 121-147 | Rot. gobo 1 shake |
| 148-174 | Rot. gobo 2 shake |

175-201 Rot. gobo 3 shake
202-228 Rot. gobo 4 shake
229-255 Rot. gobo 5 shake

Channel 3 - Gobo rotation :

0-7 No rotation
8-255 Rotation

Channel 4 - Prism rotation :

0-7 No rotation
8-127 forwards prism rotation from fast to slow
128-135 No rotation
136-255 Backwards prism rotation from slow to fast

Channel 5 - Auto Program:

0-23 Nomal
24-47 Auto Program 1
48-71 Auto Program 2
72-95 Auto Program 3
96-119 Auto Program 4
120-143 Auto Program 5
144-167 Auto Program 6
168-191 Auto Program 7
192-215 Auto Program 8
216-239 Auto Program 9
240-255 Auto Program 10

CLEANING AND MAINTENANCE

The operator has to make sure that safety-relating and machine-technical installations are inspected by an expert after every four years in the course of an acceptance test. The operator has to make sure that safety-relating and machine-technical installations are inspected by a skilled person once a year.

The following points have to be considered during the inspection:

- 1) All screws used for installing the devices or parts of the device have to be tightly connected and must not be corroded.
- 2) There must not be any deformations on housings, fixations and installation spots (ceiling, suspension, trussing).
- 3) Mechanically moved parts like axles, eyes and others must not show any traces of wearing (e.g. material abrading or damages) and must not rotate with unbalances.
- 4) The electric power supply cables must not show any damages, material fatigue (e.g. porous cables) or sediments. Further instructions depending on the installation spot and usage have to be adhered by a skilled installer and any safety problems have to be removed.



CAUTION

Disconnect from mains before starting maintenance operation

We recommend a frequent cleaning of the device. Please use a moist, lint-free cloth. Never use alcohol or solvents!



CAUTION!

The lens has to be replaced when it is obviously damaged so that its function is impaired e.g. due to cracks or deep scratches

The objective lens will require weekly cleaning as smoke-fluid tends to building up residues, reducing the light-output very quickly. The cooling-fans should be cleaned monthly. The gobos may be cleaned with a soft brush. The interior of the fixture should be cleaned at least annually using a vacuum-cleaner or an air-jet.

The dichroic color-filters, the gobo-wheel and the internal lenses should be cleaned monthly.

To ensure a proper function of the gobo-wheel, we recommend lubrication in six month intervals. The quantity of oil must not be excessive in order to avoid that oil runs out when the gobo-wheel rotates.

There are no serviceable parts inside the device. Maintenance and service operations are only to be carried out by authorized dealers.

Please refer to the instructions under "Installing/Replacing the lamp".

Replacing the fuse

If the fine-wire fuse of the device fuses, only replace the fuse by a fuse of same type and rating.

Before replacing the fuse, unplug mains lead.

Procedure:

Step 1: Open the fuse holder on the rear-panel with a fitting screwdriver.

Step 2: Remove the old fuse from the fuse-holder.

Step 3: Install the new fuse in the fuse-holder.

Step 4: Replace the fuse-holder in the housing.

Should you need any spare parts, please use genuine parts.

If the power supply cable of this device becomes damaged, it has to be replaced by a special power supply cable available at your dealer.

Should you have further questions, please contact your dealer.

TECHNICAL SPECIFICATIONS

Power supply :

100VAC,50Hz; 110VAC,50Hz; 120VAC, 50Hz; 220VAC,50Hz; 230VAC,50Hz; 240VAC, 50Hz;
 98VAC,50Hz; 110VAC,60Hz; 120VAC,60Hz; 220VAC,60Hz; 230VAC,60Hz; 240VAC,60Hz;

Power consumption : max. 400 W

Lamp : PHILIPS MSD250/2 GY9.5

Motors : 3 micro motors

Packing dimensions : 51 x 37 x 34 cm

Sound-control: via built-in microphone

Net weight : 10KGS;

Gross weight: 12KGS;

Remark : errors and omissions for every information given in this manual excepted. All information is subject to change without prior notice.

PCB wiring circuit diagram

